

HEAVY DUTY GRIP STRUT® WALKWAY CHANNELS LOAD TABLES

5-DIAMOND — 24" WIDTH — 5" DEEP

6-DIAMOND — 30" WIDTH — 5" DEEP

8-DIAMOND — 36" WIDTH — 5" DEEP

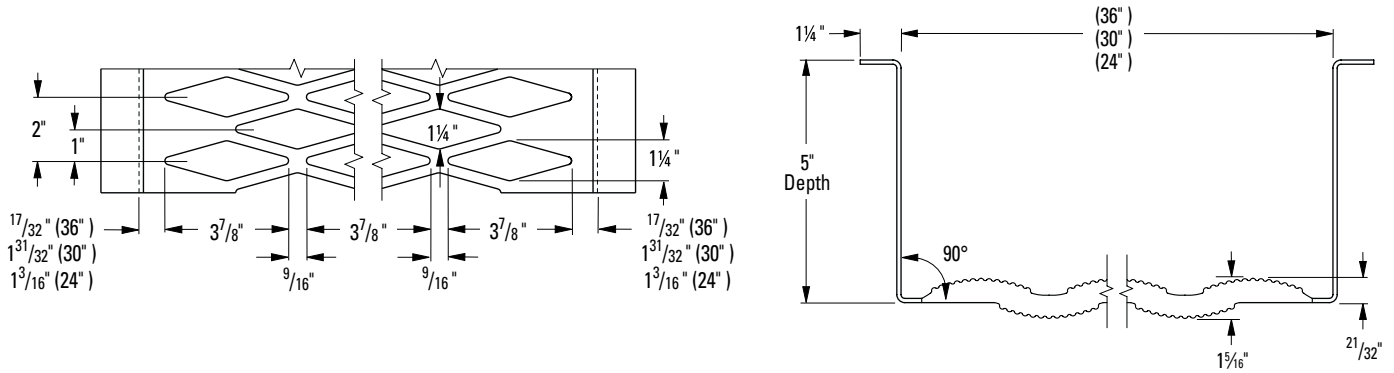

Heavy Duty Grip Strut Walkway Channels

Allowable loads and deflections: U=Uniform load (lb./ft.²) C= Concentrated load (lb.) D=Deflection (in.)

Channel Depth in.	Material Gauge	Weight lb./lin. ft.	Catalog Number	Load/Defl. Code	Span												
					4'-0"	5'-0"	6'-0"	7'-0"	8'-0"	9'-0"	10'-0"	11'-0"	12'-0"	13'-0"	14'-0"	15'-0"	16'-0"
24" 5-Dia.	11 ga.*	15.4	H-55011-W	U	750	480	334	245	187	148	120	99	83	71	62	54	47
				D	.34	.35	.38	.34	.34	.34	.35	.42	.50	.59	.69	.79	.91
				C	3000	2400	2000	1714	1500	1334	1200	1091	1000	922	857	800	750
	10 ga.	17.5	H-55010-W	U	937	600	417	306	234	185	150	124	104	89	77	67	59
				D	.38	.39	.42	.38	.38	.38	.39	.47	.56	.66	.77	.88	1.01
				C	3750	3000	2500	2143	1875	1667	1500	1364	1250	1153	1071	1000	938
	9 ga.*	19.6	H-55009-W	U	1031	660	459	337	257	204	165	136	114	98	85	74	65
				D	.38	.39	.42	.38	.38	.38	.39	.47	.56	.66	.77	.88	1.01
				C	4125	3300	2750	2357	2063	1834	1650	1500	1375	1268	1178	1100	1032
30" 6-Dia.	11 ga.*	17.7	H-65011-W	U	732	468	325	239	183	145	116	96	81	69	60	52	45
				D	.33	.39	.36	.36	.41	.38	.37	.37	.44	.51	.59	.68	.77
				C	3667	2932	2444	2095	1832	1629	1467	1333	1222	1128	1047	977	916
	10 ga.	19.9	H-65010-W	U	916	586	407	299	229	182	146	121	102	87	75	65	57
				D	.37	.43	.40	.40	.46	.42	.41	.41	.49	.57	.66	.75	.86
				C	4584	3666	3056	2619	2291	2037	1834	1667	1528	1410	1309	1222	1146
	9 ga.*	22.1	H-65009-W	U	1007	644	447	328	251	200	160	133	112	95	82	71	62
				D	.37	.43	.40	.40	.46	.42	.41	.41	.49	.57	.66	.75	.86
				C	5042	4032	3361	2880	2530	2240	2017	1833	1680	1551	1439	1344	1260
36" 8-Dia.	11 ga.*	20.2	H-85011-W	U	444	284	197	144	111	88	71	58	49	42	36	31	28
				D	.35	.35	.30	.29	.30	.32	.35	.38	.46	.54	.62	.71	.82
				C	2664	2133	1777	1524	1333	1184	1066	969	888	820	761	711	666
	10 ga.	22.7	H-85010-W	U	556	356	247	181	139	110	89	73	62	53	45	39	35
				D	.39	.39	.33	.32	.33	.36	.39	.42	.51	.60	.69	.79	.91
				C	3330	2667	2222	1905	1667	1481	1333	1212	1111	1026	952	889	833
	9 ga.*	25.3	H-85009-W	U	611	391	271	199	152	121	97	80	68	58	49	42	38
				D	.39	.39	.33	.32	.33	.36	.39	.42	.51	.60	.69	.79	.91
				C	3663	2933	2444	2095	1833	1629	1466	1333	1222	1128	1047	977	916
				D	.31	.31	.26	.26	.26	.29	.31	.34	.41	.46	.55	.64	.72

*Available on special order.



HEAVY DUTY GRIP STRUT® WALKWAY CHANNELS LOAD TABLES

5-DIAMOND — 24" WIDTH — 5" DEEP

6-DIAMOND — 30" WIDTH — 5" DEEP

8-DIAMOND — 36" WIDTH — 5" DEEP

Strut Concentrated - loads/deflection ⁽²⁾			
Walkway Width	Thickness - Material	Concentrated Cs (lb./ft.)	
		Serrated	Non-Serrated
24" 5-Diamond	11 ga. Steel	798	917
	10 ga. Steel	912	1048
	9 ga. Steel	1026	1179
	Deflection (in.)	0.08	0.07
30" 6-Diamond	11 ga. Steel	537	612
	10 ga. Steel	618	704
	9 ga. Steel	703	800
	Deflection (in.)	0.11	0.10
36" 8-Diamond	11 ga. Steel	447	510
	10 ga. Steel	515	587
	9 ga. Steel	586	667
	Deflection (in.)	0.16	0.15

Cs = Allowable concentrated load per ft. of length at mid-width (lb./ft.)
 (2) See "General Load information", in technical info., for explanation of design load deflection conditions.

Strut Uniform - loads/deflection ⁽²⁾			
Walkway Width	Thickness - Material	Concentrated U (lb./ft. ²)	
		Serrated	Non-Serrated
24" 5-Diamond	11 ga. Steel	798	917
	10 ga. Steel	912	1048
	9 ga. Steel	1026	1179
	Deflection (in.)	0.11	0.10
30" 6-Diamond	11 ga. Steel	429	490
	10 ga. Steel	494	563
	9 ga. Steel	563	640
	Deflection (in.)	0.14	0.13
36" 8-Diamond	11 ga. Steel	298	340
	10 ga. Steel	343	391
	9 ga. Steel	391	444
	Deflection (in.)	0.20	0.19

U = Allowable Uniform Load (lb./ft.²)
 (2) See "General Load information", in technical info., for explanation of design load deflection conditions.